

ADAPTIVE GRIPPERS TECHNICAL DATA

2-FINGER 85

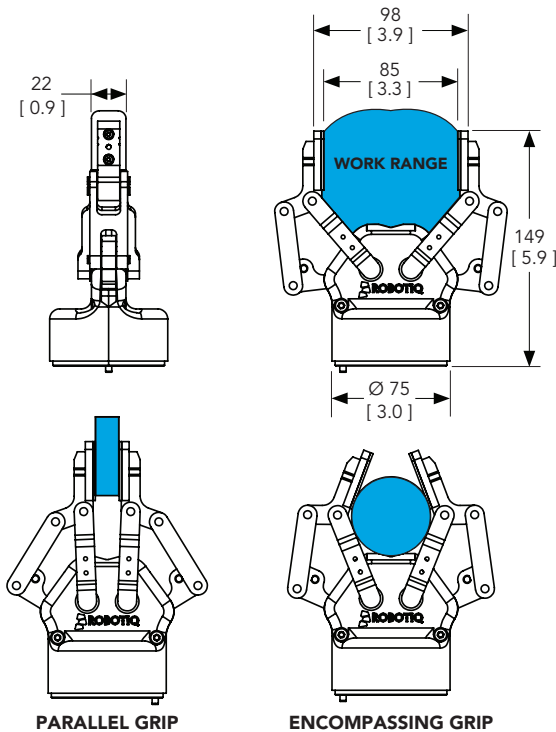

2-FINGER 140

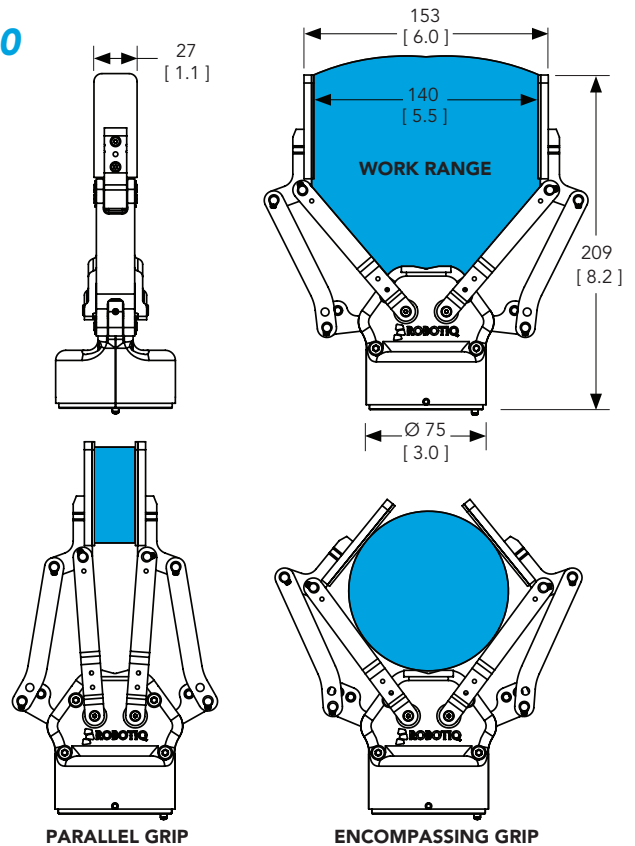

UNITS: mm
[in.]

MECHANICAL SPECIFICATIONS*

	2-FINGER 85		2-FINGER 140	
Gripper opening (see figure)	0 to 85 mm	0 to 3.3 in	0 to 140 mm	0 to 5.5 in
Object diameter for encompassing grip	43 to 85 mm	1.7 to 3.3 in	90 to 140 mm	3.5 to 5.5 in
Gripper weight with mechanical coupling	900 g	2 lbs	1000 g	2.2 lbs
Maximum recommended payload 0.3 friction coefficient between finger and steel part, safety factor of 2.6	5 kg	11 lbs	2.5 kg	5.5 lbs
Grip force**	20 to 235 N	1.1 to 49.45 lbf	10 to 125 N	2.2 to 24.7 lbf
Closing speed	20 to 150 mm/s	0.8 to 5.9 in/s	30 to 250 mm/s	1.2 to 9.8 in/s
Operating temperature	-10°C to 50°C	14°F to 122°F	-10°C to 50°C	14°F to 122°F
Parallel grip repeatability	0.05 mm	0.002 in	0.08 mm	0.003 in

* Using Flat Silicone Fingertips for 2-Finger 85 and 2-Finger 140 Adaptive Grippers

** ±15%, varies with speed and force parameters

ELECTRICAL SPECIFICATIONS

Nominal supply voltage	24 V DC ±10%
Absolute maximum supply voltage	28 V DC
Quiescent power (minimum power consumption)	<1 W
Peak current	1 A

CONTROL

Communication protocol	Modbus RTU (RS-485, Half-duplex)
Communication protocol options with controller	Ethernet/IP, Modbus TCP, PROFINET, DeviceNet, CANopen, EtherCAT
Programmable gripping parameters	Position, speed and force control
Status LED	Power, communication and fault status
Feedback	Grip detection, gripper position and motor current