

TECHNICAL DATA

FT 300

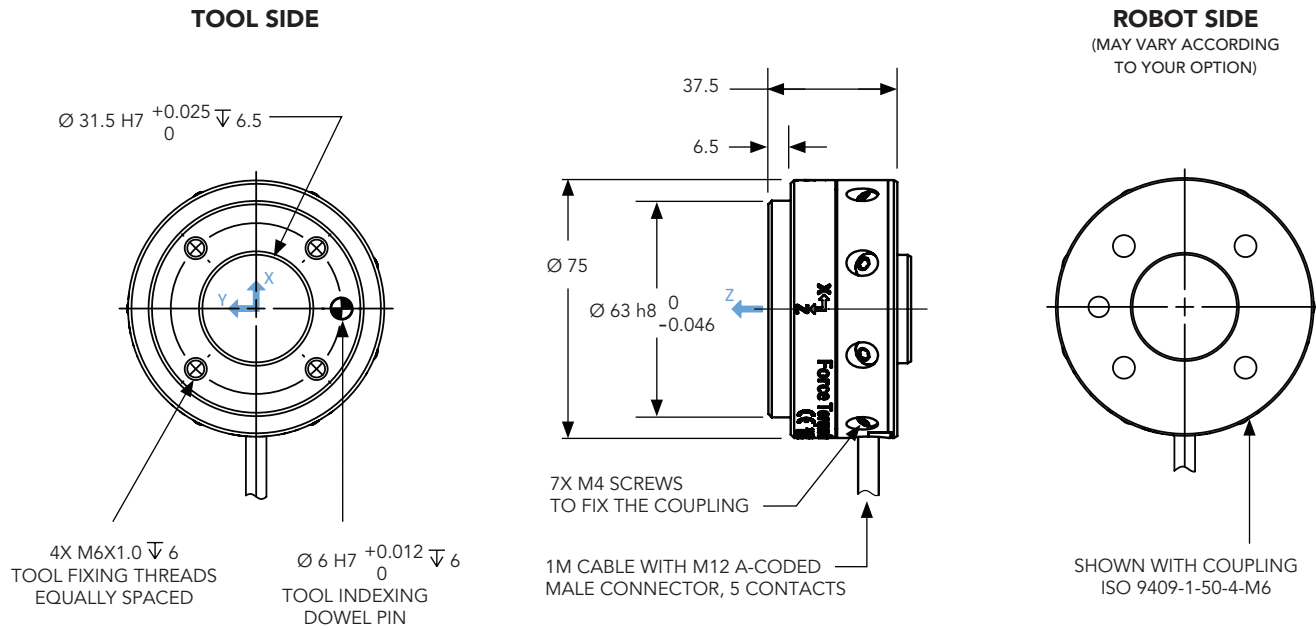

UNITS: mm

SIGNAL SPECIFICATIONS

			Recommended threshold	
Measuring range	Fx, Fy, Fz	$\pm 300 \text{ N}$		
	Mx, My, Mz	$\pm 30 \text{ N}\cdot\text{m}$		
Signal noise	Fx, Fy	1.2 N	5 N	Noise is defined here as the standard deviation of each data for 1 second for a typical steady signal.
	Fz	0.5 N	2 N	
	Mx, My	0.02 N·m	0.08 N·m	
	Mz	0.03 N·m	0.12 N·m	
External noise sensitivity	All axes	Immune		Under normal operating conditions.
Data output rate		100 Hz		
Temperature compensation		15°C - 35°C		Temperature fluctuation is compensated for within this range. Signal quality may be affected outside of this range.

MECHANICAL SPECIFICATIONS

Outside diameter	75 mm	
Thickness	37.5 mm	With Coupling ISO 9409-1-50-4-M6
Weight	300 g	With Coupling ISO 9409-1-50-4-M6
Overload capacity	500 %	Exceeding the overload capacity will permanently damage the sensor.

ELECTRICAL SPECIFICATIONS

Nominal supply voltage	4.5-28 V DC	
Maximum power consumption	2 W	
Sensor electrical interface	RS-485, USB	Software packages available for Universal Robots, ROS, Linux and Windows.